

## CROSS SMART SENSOR

### DG7-FCO: FREE CHLORINE

NON-REAGENT TYPE

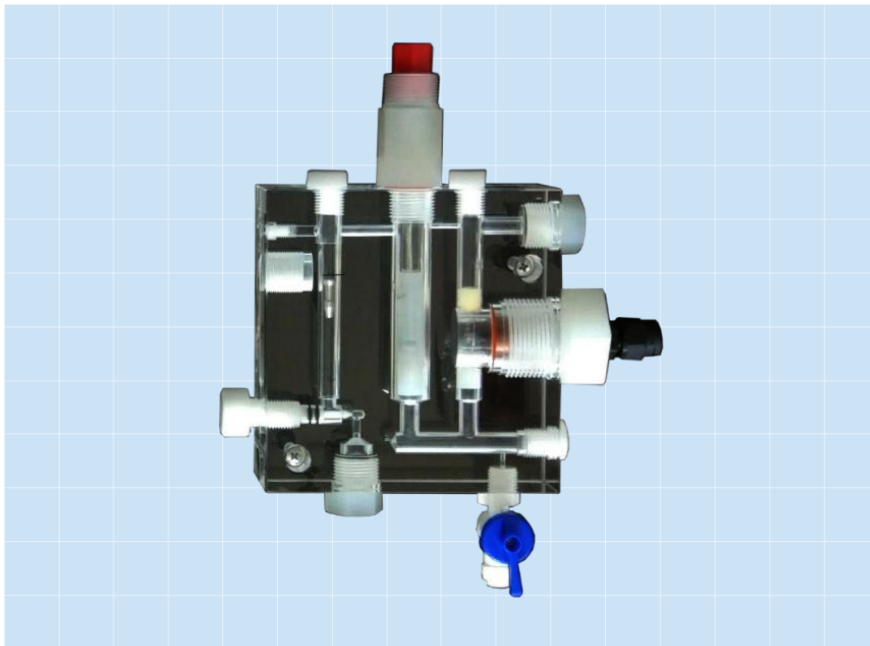

The **DG7-FCO** free chlorine sensor (non-reagent type) is used for measuring concentration of free chlorine present in sample water, such as chlorine ( $\text{Cl}_2$ ) hypochlorous acid ( $\text{HClO}$ ), and hypochlorite ion ( $\text{ClO}^-$ ).

The measuring principle of DG7-FCO sensor is analysis determination using the gold rotating electrode polarographic method. Free chlorine concentration is determined by measuring the current (diffusion current) which flows when free chlorine is subjected to electrolytic reduction by applying a voltage (applied voltage) between the indicator electrode (rotating electrode) and the silver counter electrode. The applied voltage is set in a region where concentration polarization occurs (plateau region) in polarography. In the plateau region, the diffusion current does not change even if the applied voltage changes.

In measurement practice, since the plateau region changes with free chlorine concentration, the applied voltage is compensated so that measurement can always be performed in the plateau region. Also, since the diffusion current is affected by the sample water temperature, temperature is compensated using a temperature sensor (Pt1000) incorporated in the counter electrode.

The sensor determines the free chlorine concentration by applying an applied voltage corresponding to the diffusion current between the indicator and counter electrodes and by applying temperature compensation to the diffusion current.

## DG7-FCO Sensor consist of the parts below

- Sensor flow cell (PMMA)
- Chlorine probe (non-reagent type) with glass beads cleaning.
- PH sensor for PH compensation.
- Flow control valve
- Optional flow measuring sensor
- Electronics unit with RS485 digital output by Modbus RTU protocol

Note 1: For no reagent and membrane in Chlorine probe, this sensor significantly lowers the operating cost and maintenance.

Note 2: The sensor can work with all GDC (General Display and Controller) and customer's datalogger or terminals which can receive the RS485 signals.

SPECIFICATIONS	
Measuring System	Polarographic method using rotating electrode
Range	(0 ~1/2/3; 0-5/10) mg/l, ppm
Accuracy	0.05mg/l
Resolution	0.01mg/l
Repeatability	±1%FS
Operate Temp.	41 to 113 °F (5 to 45 °C)
Temp. Compensation	Automatically, by an integrated temperature sensor
Operating Pressure	Max. 6 bar, no pressure impulses and/or vibrations
Sample Flow Rate	Max. 30L/h
pH compensation	Automatic pH measurement and compensation
Run-in Time	First start-up 2 hours
Response Time	T90: <2 min
Power	24VDC, 40mA
Digital Interface	RS485 Modbus RTU
Size & Weight	5.31x5.12x2 inch & 2 lb (135x130x50mm & 0.9 kg) with Flow Cell

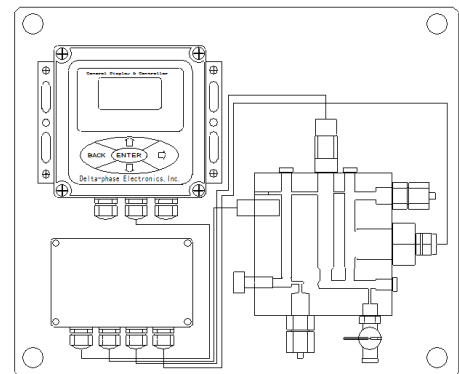

## ORDER CODE

**DG7-FCO:** Free Chlorine Sensor (non-reagent type) with panel and flow cell

- L Range for 1/2/3 ppm
- H Range for 5/10 ppm

- C1010' cable
- C2020' cable
- C3030' cable
- Other length contact factory.

DG7-FCO

-N

-C30

## TERMINALS

### GDC-01/02 Terminal

Single or dual-channels



### GDC-04/06/08 Controller

Multi-channels up to eight



### GDC-Ex Terminal

Single channel Ex-proof

